

INSTALLATION

230 Volt 13 ampere 50 Hz

The SUITMATE® Swimsuit Water Extractor has been designed and manufactured with safety as our primary consideration. Therefore, it is important that the unit be installed correctly. It is also important that the installation comply with all local building codes and regulations. Please consult your local licensed plumbing and electrical engineers or contractors about your installation. Read the entire INSTALLATION instructions before beginning your installation. Remember: *DO IT RIGHT* and *DO IT SAFE*.

PROPER LOCATION FOR THE SUITMATE

Following is a list of factors to consider in determining a location for the SUITMATE.

1. The unit should be located in an area that is near where people remove and rinse out their swimsuits.
2. The unit should **NOT** be located in a cluttered area or where it is exposed to direct shower water or water hose down.
3. The unit should be mounted on a wall structure that will support the unit's approximate 60 pounds hanging weight plus the added weight or pressure of people leaning on the unit. Consult the **PROPER WALL MOUNTING** section of these instructions to determine an appropriate location.
4. There should be a means to dispose of the waste water from the unit. Consult the **PROPER DRAINAGE** section of these instructions to determine an appropriate location.
5. The unit should be wired to a 230 volt 13 ampere 50Hz *dedicated circuit*. Consult the **PROPER ELECTRICAL CONNECTIONS** section of these instructions to determine an appropriate location.

PROPER WALL MOUNTING OF THE SUITMATE

The SUITMATE should be mounted to the wall with the Mounting Bracket that is provided with the unit. The SUITMATE INSTALLATION TEMPLATE shows the recommended location for the mounting holes, the electrical service, and the waste water outlet (if utilized). The SUITMATE Mounting Bracket must be secured to a wall stud, or to a concrete block or cinder block wall.

WARNING Anchors in drywall are not sufficient to mount the SUITMATE.

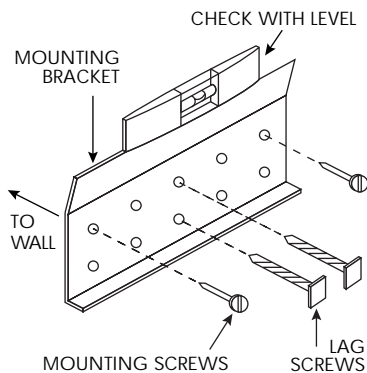

Locating and Securing the Mounting Bracket to the Wall

The recommended height from the floor to the top of the SUITMATE is 42 inches. At least an additional 10 inches of clearance above the SUITMATE is needed for the opening and closing of the Lid. This means that the top edge of the Mounting Bracket should be 39½ inches from the floor. Use the SUITMATE INSTALLATION TEMPLATE to determine a location on the wall that provides for adequate clearance, a strong and secure place for the Mounting Bracket as well as easy access to the electrical and drainage connections.

WARNING The Mounting Bracket must be level after secured to the wall.

To secure the Mounting Bracket to a stud, center the Bracket on the stud and mark on the wall or the stud the location of the two vertical center holes of the Mounting Bracket. Drill the marked locations with a 1/8 inch drill bit. Make sure the Mounting Bracket will be level after it is secured to the wall. Reposition the Mounting Bracket over the two marked center holes and mark at least one additional hole on each side of the center holes. Drill the outer two holes to receive wall anchors. Install the wall anchors.

Secure the Mounting Bracket to the stud by using two 5/16 x 2 inch lag screws through the two vertical center holes. Make sure the Bracket is level. Finish securing the Bracket with the appropriate fasteners in the outer two holes. For mounting to concrete, etc., use at least four No. 10 or larger screws fastened into appropriate anchors. After the Bracket has been anchored to the wall and the electrical and drainage requirements have been allowed for, the SUITMATE is ready to be mounted to the wall.

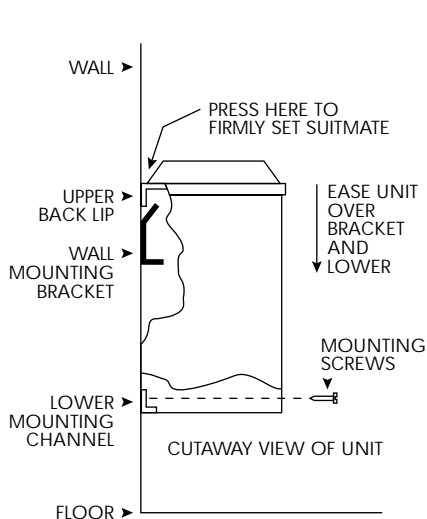

Mounting the Suitmate to the Wall

Remove all packaging material from the SUITMATE including material around the Motor and the shipping board on the bottom of the unit. The upper back lip of the SUITMATE should be lowered down and centered on the Bracket. After the unit is centered, push down on the back of the unit to make sure that it is securely wedged onto the Bracket. Make sure the unit is level. If it is not level, remove the unit, adjust the Mounting Bracket and re-hang the unit. A level installation is necessary to minimize vibration and insure proper drainage of waste water. Using appropriate fasteners and anchors on the lower mounting channel at the bottom rear of the unit, finish securing the unit to the wall. This will prevent the unit from being lifted from the Bracket or being moved.

PROPER DRAINAGE FOR THE SUITMATE

Note: *Strictly follow all applicable local plumbing codes and regulations.*

To a Floor Drain

Drainage of the waste water to a floor drain should be done *ONLY* in an area where the floor is normally wet. *DO NOT* drain water across a floor where people do not expect to encounter a wet and slippery condition. SUITMATE comes with a short flexible floor drain extension tube connected with a stainless steel hose clamp to its drain tail piece.

WARNING The drain tube that comes with the unit must not be removed unless the unit is connected to an approved waste water outlet or the factory supplied tube is replaced with another tube according to the following instructions.

Replacing the Factory Drain Tube with a Longer Drain Tube

Use a 1 1/4 inch I.D. drain tube with a smooth interior that will not crimp or collapse. Use the stainless steel hose clamp that is provided with the factory flexible floor drain extension tube to secure the replacement tube to the unit's drain tail piece. Run the drain tube so that it is never higher than the bottom of the SUITMATE and always slopes down. Secure the drain tube to the wall or floor with properly sized "U" clamps so it cannot be maneuvered to trap waste water. Cut off the end of the drain tube on an angle to help prevent it from being blocked by the floor, wall, or some other object. Upon completion of the installation, check to make sure that there is a free flow of water from the drain tube extension.

To an Approved Sanitary Waste Line

This installation should only be done in accordance with all applicable local plumbing codes and regulations. The unit's 1¼ inch O.D. drain tail piece is designed for connection with standard compression type plumbing fittings. There is room inside the housing for the use of a standard "P" type plumbing connection. The waste outlet should be located in the wall behind the unit. The SUITMATE INSTALLATION TEMPLATE shows the appropriate location for the waste outlet.

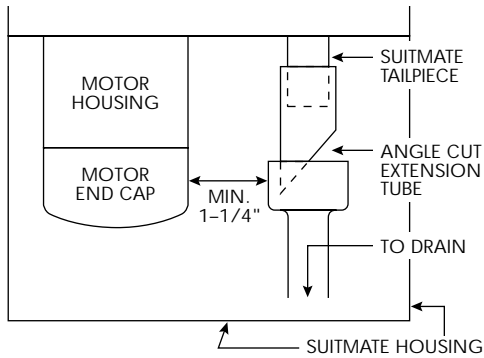

If an open-site drain connection is required and the open site is to be positioned within the SUITMATE housing, locate the top of the receiver pipe below the top of the Motor end cap, and locate the top outer edge of the receiver pipe at least 1¼ inch from the body of the Motor. (See also the SUITMATE INSTALLATION TEMPLATE.) Be sure that the cut off end of the drain extension tube is below the top of the receiver with the angle cut facing away from the Motor as illustrated.

PROPER ELECTRICAL CONNECTIONS FOR THE SUITMATE

Note: Strictly follow all applicable local electrical codes and regulations.

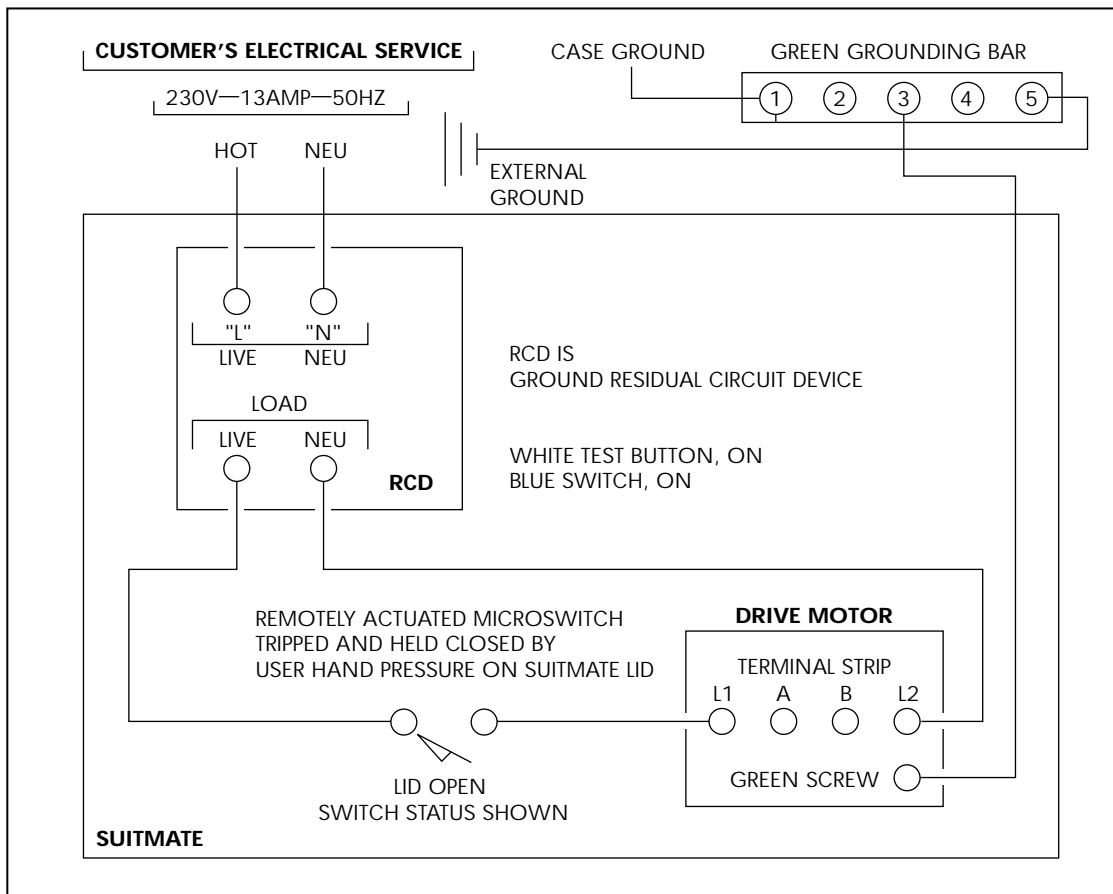

SUITMATE is equipped with a ground residual circuit device (RCD) and is designed to be connected to a 230 volt 13 ampere 50Hz dedicated circuit that is protected by a fuse or circuit breaker. A PLUG-IN INSTALLATION IS NOT ACCEPTABLE. The utilized circuit must be run to the SUITMATE weatherproof RCD Junction Box which contains

the RCD. A liquid tight raceway should be used from the circuit connection to the RCD Junction Box. The SUITMATE INSTALLATION TEMPLATE shows the location of the suggested area behind the unit for the entrance of the electrical raceway that does not interfere with the drainage connection.

WARNING Do not route the raceway where waste water can flow or drip on it.

Remove the cover of the weatherproof RCD Junction Box which contains the RCD and remove the RCD. The circuit ground conductor must be connected to the green grounding bar located in the RCD Junction Box. If no ground is available on the circuit utilized, you must provide a proper ground for the SUITMATE. The live and neutral leads of the power circuit should be connected to the RCD terminals marked "L" (live) and "N" (neutral). Connect the live lead to the terminal marked "L" (live) and the neutral lead to the terminal marked "N" (neutral). After the correct electrical connections have been properly made, remount the RCD. Reinstall the weatherproof RCD Junction Box cover previously removed. This cover provides access to the RCD "TEST" button.

POSTING THE WALL SIGN

It is important that the wall sign included in the INSTALLATION PACKAGE be mounted on the wall above the unit. Locate the bottom edge of the sign six inches above the SUITMATE. At this height the sign will not be blocked when the Lid is raised. It will also serve as a stop to keep the Lid from striking the wall behind the unit.

The sign has an adhesive foam strip around the perimeter of the back side. Be sure the surface that the sign is to be mounted to is clean and dry. Peel off the protective strip to expose the adhesive foam. Without touching the sign to the wall, align the sign six inches above the unit and at its center. Press the sign to the wall and rub firmly over the adhesive portion of the sign.

TESTING AND OPERATION

After the mounting and all connections are complete, test the SUITMATE as follows:

1. Make sure all packaging material is removed from the unit including material around the Motor and the shipping board on the bottom of the unit.
2. Check to see that the Basket is empty and that the Lid moves freely.
3. Press down on the Lid and hold down for several seconds. The unit should run smoothly and there should be no excessive vibration or noise.
4. Release and lift the Lid from the down position. The Basket should stop rotating within a second or two.
5. Test the SUITMATE by putting a wet swimsuit in the unit according to the instructions on the underside of the Lid. If there is excessive vibration or noise it is usually caused by the improper loading of the swimsuit. Be sure that the swimsuit is pushed to the bottom of the Basket and that all material is at least two inches below the top of the Basket.

INSTALLATION TROUBLESHOOTING

If the SUITMATE does not operate, check the following:

1. Check to see if there is power to the unit. Check the circuit using an A.C. voltmeter set to the appropriate range; measure across the "LINE" side of the GFCI.
2. Make sure that the GFCI switch is in the "ON" position. The red button must be depressed to turn on the GFCI.
3. Check the connections in the GFCI Junction Box. Be sure there is power on the "LOAD" side of the GFCI.
4. Check the SUITMATE TROUBLESHOOTING section in this manual for additional troubleshooting assistance.

FINISHING THE INSTALLATION

Be sure to save this SUITMATE MANUAL along with all the other materials included in the INSTALLATION PACKAGE envelope. If you did not receive all the materials listed or need additional information, call the Extractor Corporation at 800-553-3353. With proper installation, use, and maintenance your SUITMATE® Swimsuit Water Extractor will provide you with years of trouble-free service.